

EDISON PARTY SYSTEM L215

LED Illuminated Wireless Speaker System

PROFESSIONAL



- ### PSL215 Features
- ◆ 6000 Watts PMPO
 - ◆ Top Ceiling & Wall Disco Light Show
 - ◆ Speakers LED Illuminated Twin 15" Woofers & (2) 1.5" Tweeters
 - ◆ Metal Speaker Grill Covers
 - ◆ Dual Channel DJ System
 - ◆ Bluetooth Wireless Pairing (X2)
 - ◆ Play back from USB (X2), SD (X2), FM (X2)
 - ◆ Karaoke
 - ◆ LED Information Display
 - ◆ Equalizer ◆ Fader
 - ◆ Wheels ◆ Side Grips
 - ◆ Microphone Input (X2) 6.3mm
 - ◆ Remote
 - ◆ Resistance 4 ohm
 - ◆ Frequency 20Hz- 20KHz
 - ◆ Power Source: AC 110V/60HZ

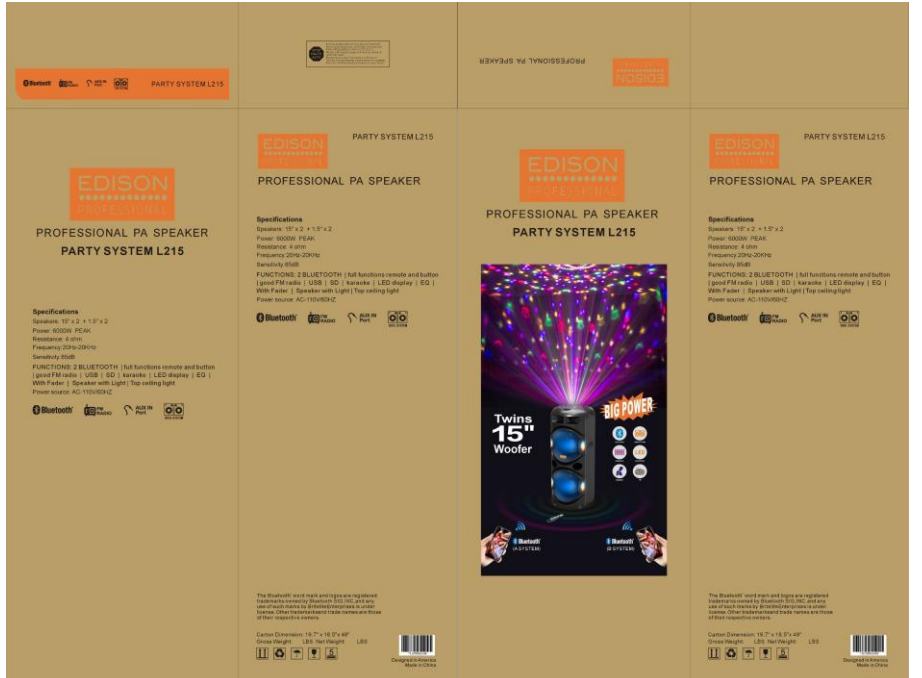

46.3"

49.0"

Unit Dimension
 18.1" W x 14.3" D x 46.3" H)
 Unit Weight
 74.7 lbs.



18.1"

Carton dimensions:
 19.7" x W 18.5" D x 49.0" H
 Carton Weight xx.x lbs. 19.7"



Remote

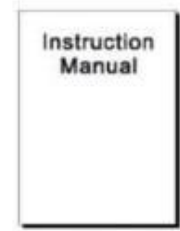

Manual



FM Antenna



Audio Cable



SPECIFICATIONS

<u>AUDIO</u>	
Speaker Construction	High performance molded body with metal speaker grill
Power Output	6000 Watts PMPO
Speaker Unit	Twin 15" Woofers & (2) 1.5" Tweeters
Resistance	4 ohms
Power Amplifier	Highly efficient class D architecture
Sensitivity	85dB
Frequency Response	20Hz – 20kHz
Microphone	N/A
<u>COMPATIBILITY</u>	
Bluetooth 2.1 & above music device (typically found on laptops, smartphones, music players and other wireless enabled devices)	
<u>MEASUREMENT</u>	
Dimension	18.1" H x 14.3" D x 46.3" H
Weight	74.7 lbs.
<u>INTERNAL POWER SUPPLY</u>	
AC 110V/60HZ	

FEATURES

LED Illuminated Wireless Speaker System, Twin 15" Woofers & (2) 1.5" Tweeters, 6000 Watts PMPO, Dual Channel DJ System, EQ, Fader, Metal Speaker Grill Covers	
Top Ceiling & Wall Disco Light Show, Bluetooth Wireless Pairing (X2), Play back from USB (X2), SD (X2), FM (X2)	
<u>ACCESSORY</u>	Remote,, Operation Manual, FM Antenna, Audio Cable

CONTROL & CONNECTION

Main power switch	On / Off Top Mounted
Bluetooth Pairing	Press the main body
Volume Control	Touch keys on top
Answer-call Button	Press the main body
FM Antenna jack	Back

STANDARDS & COMPLIANCES

<u>TERRITORY</u>	<u>AGENCY APPROVAL</u>	<u>RATING LABEL</u>	
General	ROHS/BQB	 <p>*Other language version of rating label can be produced upon request.</p>	
N. America	UL / cUL		FCC
Europe	TUV, BS		CE / EMC
Australia (on request)	SAA		C-Tick
China	CCC		SRRC
Taiwan	BSMI		NCC
Bluetooth	BQB, Product Listing		

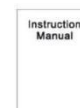



1. Power ON/OFF
2. A System SD card input slot
3. A System USB input slot
4. A System Line input slot
5. Microphone 1 input slot
6. 1KHz Equalizer
7. 63Hz Equalizer
8. Treble increase/weakers
9. BASS increase/weakers
10. A System Volume control
11. A System BT input key
(BT searching name: EDISON L215 A)
12. A System USB/SD card input key
13. A System Line input key
14. A System Play/Pause key
15. A System FM input key
/long press for FM auto scan
16. A System Previous key,
long press for volume decrease
17. A System next key,
long press for volume increase
18. Mute of whole unit
19. A System LED display

20. Remote control receiver
21. B System LED display
22. LED switch ON/OFF:
Unit power is ON ,aLL lights ON
1st press: Top Ceiling light OFF / Speaker Light & Decoration LED ON
2nd press: Top Ceiling light ON / Speaker Light & Decoration LED OFF
3rd Press: All Lights OFF
4th Press: All Lights ON
Rotate Operation
23. B System Previous key, long press for volume decrease
24. B System next key, long press for volume increase
25. B System Line input slot
26. B System Play/Pause key
27. B System FM input key
/long press for FM auto scan
28. B System BT input key
(BT searching name: EDISON L215 B)
29. B System USB/SD card input key
30. B System Volume control
31. ECHO increase/weakers
32. Microhone Volume increase/weakers
33. 12KHz Equalizer
34. 6KHz Equalizer
35. Microphone 2 input slotase
36. B System Line input slot
37. B System USB input slot
38. B System SD card input slot

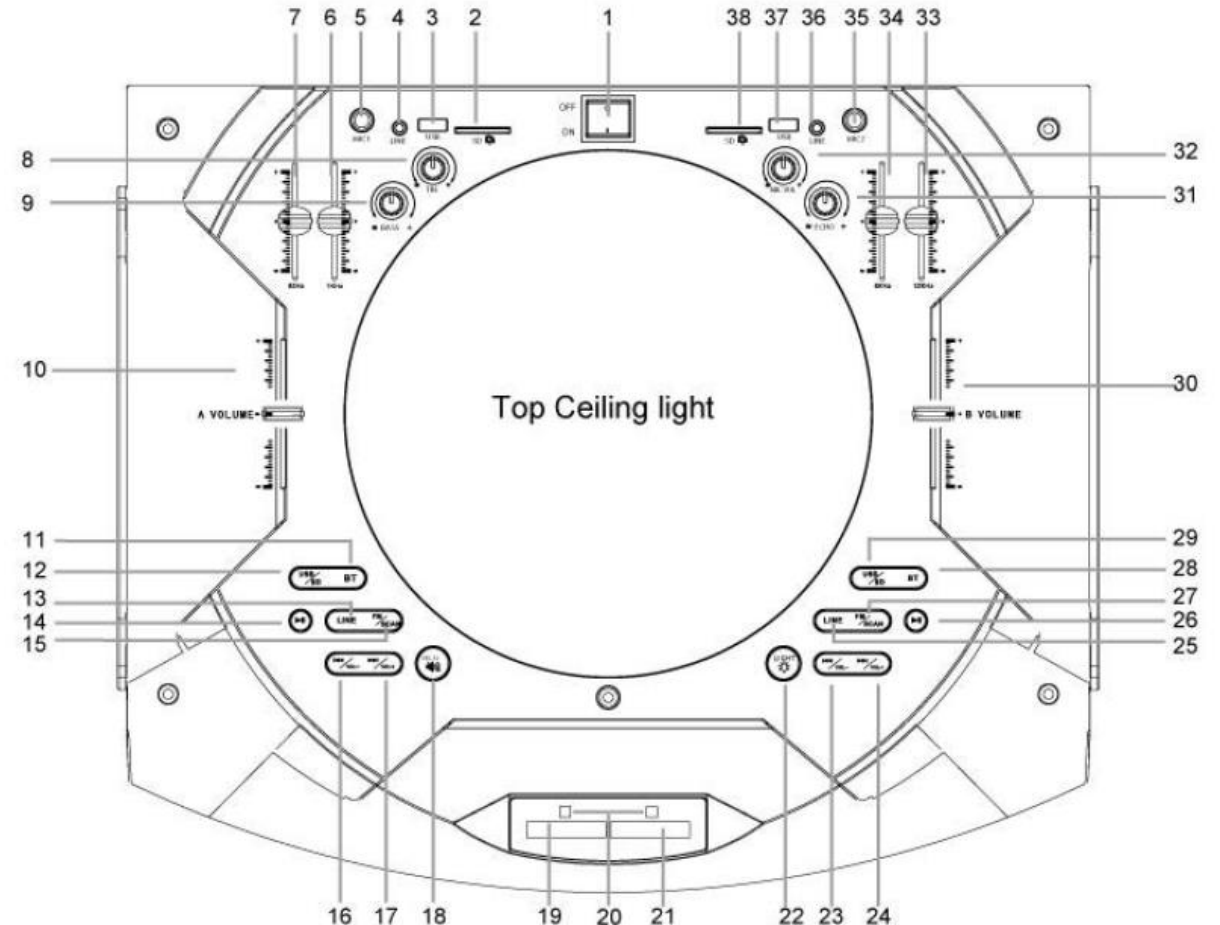

EDISON PARTY SYSTEM L215

PROFESSIONAL

LED Illuminated Wireless Speaker System

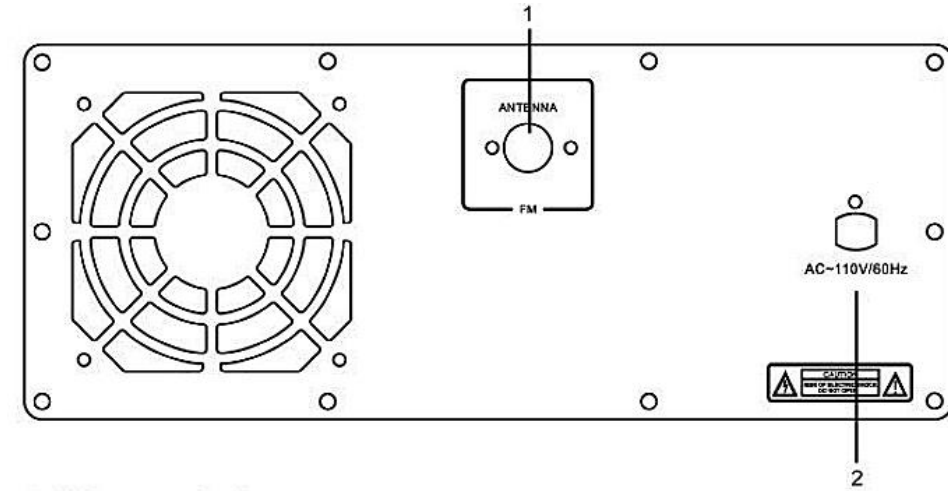
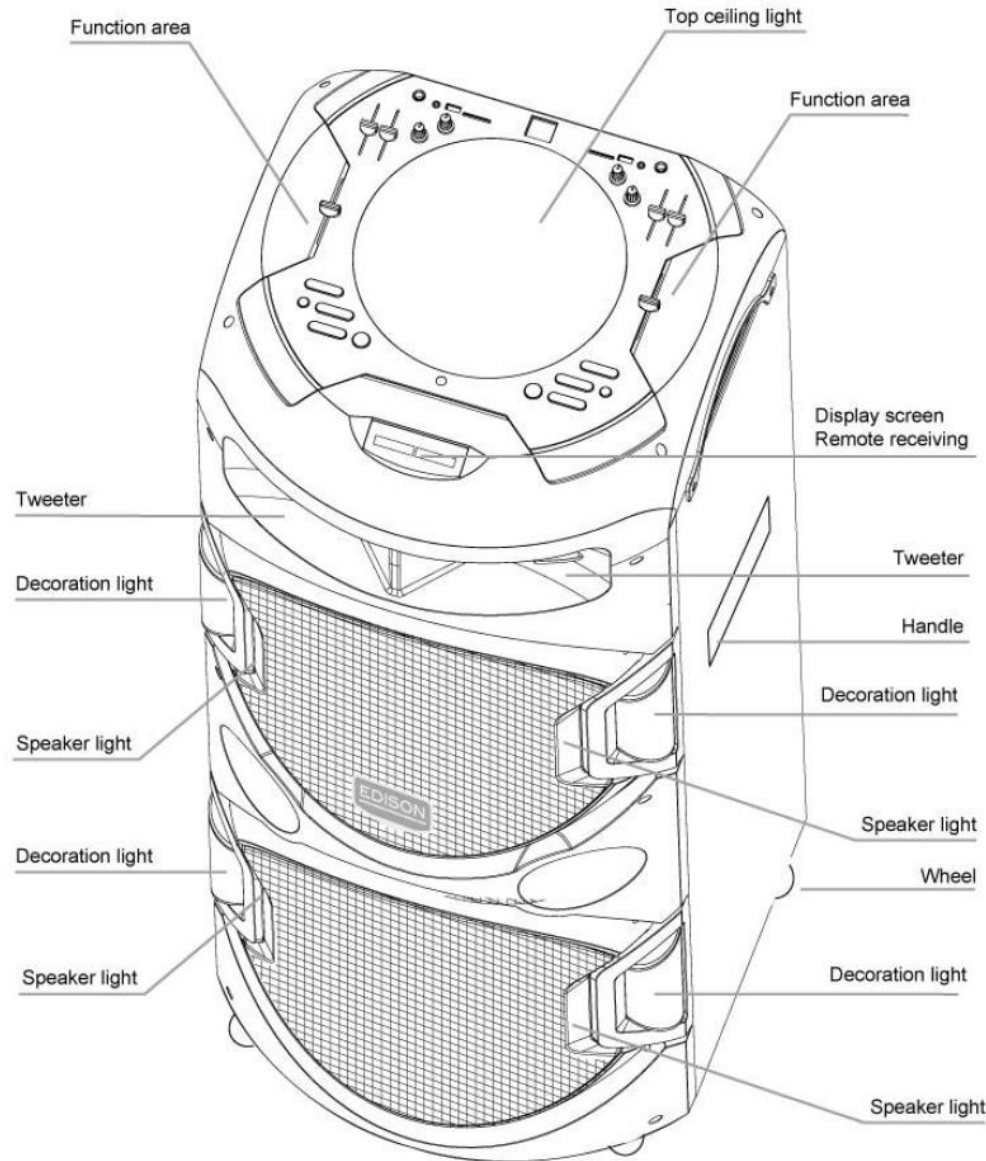

1. FM antenna jack
2. Power input