

HIGH-LIGHT WHITE MATTE

ISLAND RANGE HOOD



A BEAUTIFUL NEW CEILING MOUNTED HOOD WITH ADVANCED FEATURES. THE HIGHLIGHT HOOD FEATURES A WHITE MATTE PANEL THAT FITS INTO THE CEILING WHILE EXTRACTING ANY IMPURITIES WITH ITS PERIMETER ASPIRATION. A LED LIGHT STRIP ILLUMINATES YOUR TASK SPACE WHILE IMPROVING ENERGY EFFICIENCY.

New!



AVAILABLE MODELS

model #	size / color	CFM*
HILTI36WHNB	36 White Matte	choose

* choose a blower	CFM	sones
IB300 (Internal)	300	1.0 - 3.0
IB400 (Internal)	400	1.0 - 4.0
IB600 (Internal)	600	1.0 - 7.0
RB900 (Remote)	900	
RB1200 (Remote)	1200	
AXP250 (In-Line)	735	

KEY FEATURES



Perimetric Filter System
The white matte panel increases efficiency and decreases noise levels



Remote Control (included)
Control all features of the hood from the convenience of a wireless remote control



Pro Motor
The motor in this hood is surrounded in metal with all metal impellers for top performance

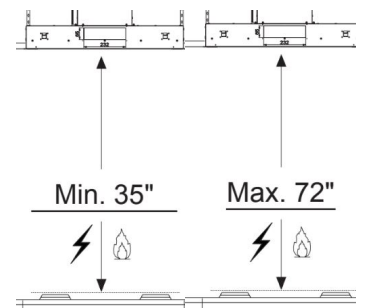

Installation Flexibility
Mounting flexibility above the cooktop 35" - 72" height off the stove

HIGH-LIGHT WHITE MATTE

ISLAND RANGE HOOD



DIMENSIONS

min / max ceiling height	5' 11" - 9' (up to 72" above the stove)
convertible to ductless / recirculating	yes - kit sold separately
hood width depth (36")	35 7/16" w 18 1/2" d
controls	4 Speed LED Digital Touch Control
lighting	4 X 1 (W) LED
ducting	6" round -4 Way side Vent / 10" top only
grease filters	dishwasher safe mesh
Perimetric Filter/ SilentKit	yes
24 hour anti-pollution mode	yes
10 minute intensive speed	yes
30 minute auto shut off	yes
filter wash alarm	yes
ADA compliant	yes (with included remote control)
AC power	400 watts / 3.2 amps

Overall Dimensions

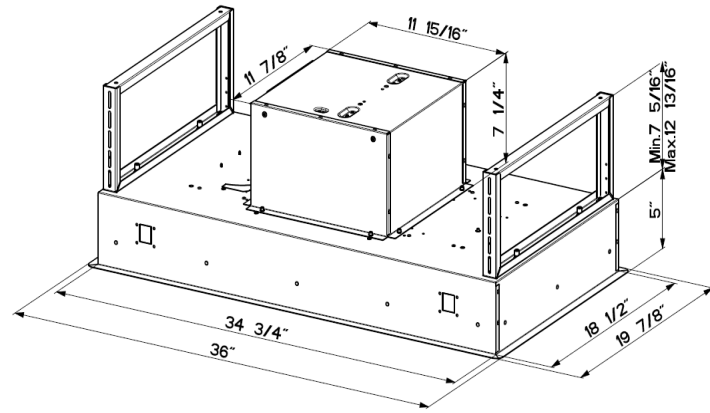

PERFORMANCE (IB600)

	SPEED	1	2	3	BOOST
CFM		150	300	450	560
Sones		3.9	5	6.0	7.3

Ceiling Cut Out

See image with dimensions for ceiling cutout.

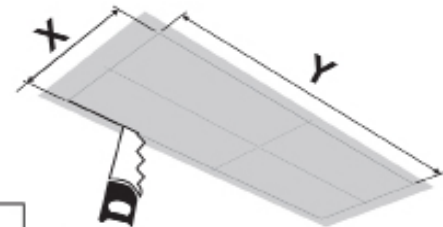

Hood	X	Y
36"	18 11/16"	34 9/16"

ACCESSORIES

FILTER1- Charcoal Filter Kit

High quality charcoal filter for use when recirculating the air back into the kitchen. Filters out odor and should be replaced every 6 months

FILTER1LL - Long Lasting Charcoal Filter Kit

New washable charcoal filter can be recharged and washed up to 8 times. For use when recirculating the air back into the kitchen. Filters out odor and can last up to 4 years

FLANGE10- 10" Plate for External Blower (For use with AXP250 only)

A 10" plate for connecting the remote blower to 10" round ducting. This is required for AXP250 & non-Faber remote blowers.

MUDAMPER6 / MUDAMPER8 / MUDAMPER10 - Universal Make-Up Air Damper

Satisfies make-up air requirements, this kit uses an air switch to activate the make-up air damper to open and bring fresh air into the home when the hood fan is on. It then closes tightly when the hood is off. The CFM level is not reduced with this accessory.

